

GH70

HIGH SPIN
WASHING MACHINE

PROFESSIONAL WASHER EXTRACTOR

Features

Durable steel drum and tank

Washing machine with steel drum and tank. The only material that guarantees durability over time and allows for a professional and intensive use of the equipment.

Floating front with no joint gasket

A solution adopted in all professional appliances. A component that is usually subject to wear, water leaks and ongoing maintenance have been eliminated. It is also easier to load and unload the laundry.

Connection supply for hot and cold water

Like all professional models, also the GH70 washing machines have a double inlet for hot and cold water. A 30% reduction to washing cycle times and running costs.

Technical solutions like the ones featured in industrial appliances

Materials such as steel, four-fold suspensions with shock absorbers, induction motor and inverter technology, 4 anchorage points for the seats of the ball bearings. These are just some of the features these models share with the industrial range.

Cycle length

The focus on energy consumption, both in terms of power absorbed and power installed, has allowed us to optimise the duration of washing cycles. Household dimensions and industrial times, with the option of setting alternative heating powers through a piece of software to meet any kind of need.

Electronic touch control, multifunction knob, integrated diagnostics

Finally, a further advantage derives from the electronic control which also in this case meets professional requirements.

Integrated self-diagnostics and storage of errors and cycles performed, to simplify and reduce technical assistance costs. 25 languages available and up to 50 washing programs.



Industrial performances in household dimensions

It's true! We have encapsulated a technology capable of meeting all the needs in the space of a household appliance.

This is the ideal solution for those requiring professional quality, but who do not have large amounts of laundry to treat: hair salons, spas, sports centres, camping sites, pizzerias and small family-run restaurants, along with small resorts.

For more demanding customers there is the version fitted with a discharge valve, which is even quicker and more reliable.



Models GH

		GH70	GHV70
Ratio capacity	1:10 / 1/9	6.0 / 6.7	6.0 / 6.7
Drum size	Diameter (mm)	480	480
	Depth (mm)	33.2	33.2
	Volume (dm ³)	60	60
Door size	Diameter (mm)	300	300
Drum speed / G Factor	rpm	50 ÷ 1400 / 530max	50 ÷ 1400 / 530max

Net and package dimension

Net dimension	Width (mm)	595	595
	Depth (mm)	591	591
	Height (mm)	845 ÷ 865	845 ÷ 865
Package dimension	Width (mm)	640	640
	Depth (mm)	661	661
	Height (mm)	920	920
	Volume (m ³)	0.40	0.40
Net and gross weight	kg	76.5 ÷ 79.7	77 ÷ 80.2

Water connection and consumption

Water feeding	kPa (bar)	300 ÷ 500 (3 ÷ 5)	300 ÷ 500 (3 ÷ 5)
Inlet water diameter	Inches	3/4	3/4
Water inlet	Number	2	2
Drain diameter	Inches	1	2
Drain type		Drain pump	Drain valve (Gravity drain)
Water consumption*	Hot water (lt)	8	8
	Cold water (lt)	40	40
	Total (lt)	48	48

Electrical data

Power supply	V / ph / Hz	208-240V 1~60Hz	
		380-415V~3N 50/60Hz	380-415V~3N 50/60Hz
		440V~3N/ 60Hz	440-480V~3 50/60Hz
Heating power	kW	3.2	3.2
Motor power	kW	0.2	0.2
Total power	kW	3.4	3.4
Fuses	A	10 ÷ 16	10 ÷ 16
Noise	dB	<65	<65

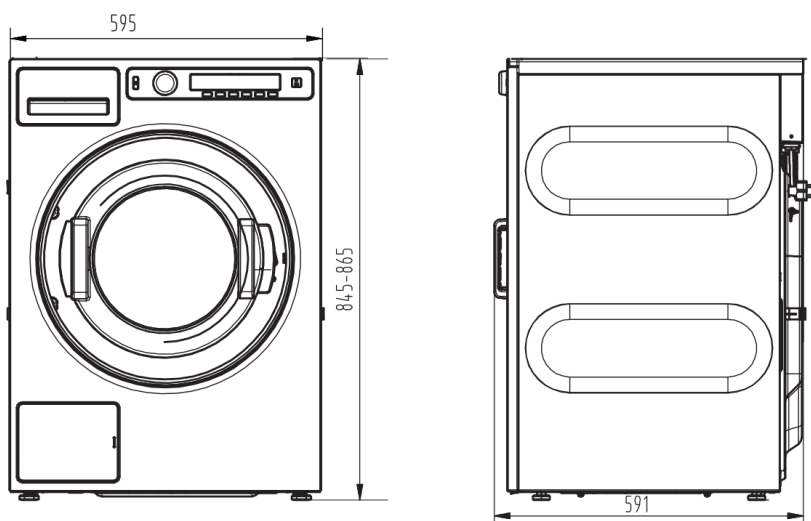

Provide GFCI (differential switch) Class "B" once the appliance is installed

*The standard ISO9398 provides for the examination of the performance of the machine as a function of a wash cycle composed of a washing phase at 60°C, 3 rinse phases and a final spin at full power, corresponding to a load equal to a nominal capacity with a 1:10 ratio, of towels cotton fabric weighing 420g/m² with dimensions of 60cm x 90cm.

GH70 - GHV70 202105 rel.01 REF. GRO000000B012

The manufacturer declines all responsibility for any inaccuracies contained in this catalogue. The manufacturer reserves the right to bring, without warning, any modifications he might believe necessary, without changing the essential characteristics of the product.

Grandimpianti i.l.e - Aligroup S.r.l. a Socio Unico
via masiere, 211/c - 32037 sospiolo (BL) Italy
ph. +39 0437 848 711 - fax +39 0437 879 108
www.grandimpianti.com - info@grandimpianti.com



COMPANY WITH
MANAGEMENT SYSTEM
CERTIFIED BY DNV GL
= ISO 9001 =
= ISO 14001 =
= ISO 45001 =

an Ali Group Company



The Spirit of Excellence